

Chalmers University of Technology
Department of Signals and Systems
Automatic Control Group

Exam questions for Linear Control System Design, SSY285

April 22nd, 2014

Cover page

1. Timeframe: 4 hours.
2. Teacher: Balazs Kulcsar, Chalmers internal phone number: 1785
3. 20 points can be reached in total (half of a point, i.e. 0.5, can also be obtained). Note, exam grades will only be approved if all assignments and the lab have been approved by the TA too. Lic/PhD students have to reach at least 12 points to pass. For Msc students Table 1 shows the grading system.

Table 1: Grading for Msc students

Points	Grade
8...11.5	3
12...15.5	4
16...20	5

4. During this written exam, it is *optionally* permitted to use printed materials such as (teacher(s) will show up and do inspection):
 - Either of the course textbooks: (hardcopy or plain printed version, without notes inside!) *Feedback systems, an introduction for scientists and engineers* by K. J. Åström and R. M. Murray, ISBN-13: 978-0-691-13576-2 or *Reglerteknikens grunder* by Bengt Lennartson, ISBN: 91-44-02416-9.
 - 1 piece of A4 paper, with *hand written* notes on both sides.
 - Pocket calculator (non-programmable, cleared memory, without graphical plotting function). Additionally to Chalmers' rules Casio fx-991 types are allowed.
 - Mathematical handbook Beta.
5. Note that phones, tablets, computers, any other communication devices are not allowed to use during the exam session. Teacher(s) will show up in person during the examination in the first and last 60 min.
6. Examination results will be advertised on May 5th 2014 (pingpong.chalmers.se). Inspection of results on May 5th and 6th 2014 10-11 am, E-building floor 5, room 5414.

Good luck!

Questions

1. Given the following system representation

$$\begin{aligned}\dot{x}_1(t) &= 10x_2(t) - x_1(t) + u_1(t) + u_2(t) \\ \dot{x}_2(t) &= u_1(t) - 2u_2(t) - 4x_2(t) \\ y_1(t) &= 5x_1(t) + 2u_1(t) \\ y_2(t) &= x_1(t) + x_2(t)\end{aligned}$$

- a) Draw the block-diagram of the dynamic system, including integrators, input and output signals (**1 point**).
- b) Find the coefficient matrices of this linear system (A, B, C, D), compute the transfer function matrix $G(s)$ (**2 point**).
- c) Find the poles and the zeros of $G(s)$. Based on $G(s)$, is this a non-minimum phase representation? Is the system input-output stable? Motivate your answer (**2 point**)!

2. Given the following state space representation by,

$$\begin{aligned}\dot{x}(t) &= \begin{bmatrix} 1 & a+b \\ 0.5 & a \cdot b \end{bmatrix} x(t) + \begin{bmatrix} 1 \\ 0.5 \end{bmatrix} u(t) \\ y(t) &= [1 \quad 0] x(t) + (a \cdot b)u(t)\end{aligned}$$

where a, b are real valued finite scalars.

- a) Find value(s) of a and b such that the state-space representation becomes of non-minimal order (**2 point**).
- b) With $a = 0.5, b = 1$ find the transformation matrix T that transforms the above state-state representation to reachable/controller canonical form. Calculate the values $\tilde{A}, \tilde{B}, \tilde{C}, \tilde{D}$ with the help of the transformation T (**3 point**).
3. Consider the following continuous time system given by a state space representation as,

$$\begin{aligned}\dot{x}_1(t) &= x_2(t) + u(t) \\ \dot{x}_2(t) &= u(t) \\ J(u) &= \int_0^\infty \left(x^T(t) \begin{bmatrix} 1 & 0 \\ 0 & 1 \end{bmatrix} x(t) + u^2(t) \right) dt.\end{aligned}$$

- a) Find the optimal (steady-state LQR) feedback gain (\bar{K}) that minimizes $J(u)$ by applying the diagonal solution structure as $\bar{P} = \begin{bmatrix} p_1 & 0 \\ 0 & p_2 \end{bmatrix}$ (**1 point**).
- b) Compute the closed-loop optimal poles (**1 point**).
4. Consider the following time discrete problem by,

$$\begin{aligned}x(k+1) &= -x(k) + v_1(k) + 2v_2(k), \\ y_1(k) &= 0.2x(k) + w_1(k), \\ y_2(k) &= 0.1x(k) + w_2(k),\end{aligned}$$

where the scalar noise intensities are $r_{w_1} = 1, r_{w_2} = 0.1, r_{v_1} = 1, r_{v_2} = 1$. All noises are normally distributed uncorrelated white noise sequences.

- a) Find the optimal steady state Kalman filter gain \bar{L} to minimize the "delayed" state error covariance, $\bar{p} = E\{\tilde{x}(k|k-1)\tilde{x}(k|k-1)^T\} > 0$ (**2 point**).
- b) Find the closed loop system observer's pole, i.e. thereof the $A - \bar{L}C$ with previously obtained gain \bar{L} . Is the observer stable? (**1 point**).

5. Given the closed loop system as shown in Figure 1 with the nominal plant transfer functions $G_n(s)$,

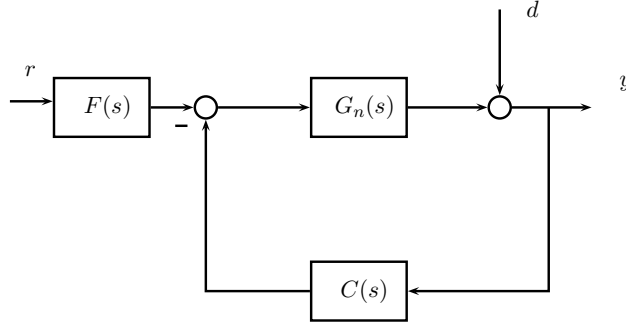

Figure 1: Closed-loop block diagram

controller $C(s)$, and pre-filter $F(s)$,

$$G_n(s) = \frac{3(s+3)}{(s+2)(s+1)}, \quad C(s) = c \cdot (s+1), \quad F(s) = \frac{1}{s+3}$$

with $c > 0$ scalar.

(a) Find the nominal transfer function matrix $T(s)$ where $y = T(s) \begin{bmatrix} r \\ d \end{bmatrix}$ (**1 point**).

(b) Find the value c which provides under $d = 0$ asymptotic step reference tracking (**1 point**).

(c) Given the real plant as $G(s) = \frac{s+1}{(s+1)^2(s+2)^2}$, find the multiplicative and additive uncertainty functions associated to the nominal plant $G_n(s)$. (**1 point**).

6. *(challenging exercise) Given the system dynamics and the performance index as,

$$\begin{aligned} \dot{x}(t) &= -1.5x(t) + \sqrt{2}u(t) + d(t) \\ y(t) &= 2x(t) \\ J(u, d) &= \int_0^\infty (y^2(t) + u^2(t) - \gamma^2 d^2(t)) dt \end{aligned}$$

where $d(t)$ is a 2-norm bounded but time varying disturbance signal. Find the stabilizing, state-feedback and optimal min-max solutions by the modified CARE if $\gamma = 1$. Find both $u^*(t)$ and $d^*(t)$ (**2p**).