

Examination**ENM061 Power Electronic Converters****Date and time**Wednesday January 11th, 2017, 8:30 – 12:30**Teacher responsible:**

Andreas Andersson/ Mebtu Beza, tel. +46729707217/+46317721617

Authorised Aids:

Chalmers-approved calculator (Casio FX82..., Texas Instruments Ti-30... and Sharp EL-W531...)

Grades:

U, 3, 4 or 5. (The limit for 3 on the exam is 20p, 4 is 30p and 5 is 40p. The maximum number of points is 50p.)

The questions are not arranged in any kind of order and a formula sheet is attached in the last page.

For those of you, who want the result of this exam to be reported to ENM60 (a previous version of the course), please write the course code 'ENM060' on the cover of the exam answer sheet. All others who sit for the ENM061 exam should write the course code 'ENM061' as expected.

1) Briefly answer the following questions. (6 points)

- What is the difference between a schottky diode, a rectifying diode and a switching diode?
- Using the ideal voltage-current characteristics, describe the difference between a MOSFET and an IGBT?
- Describe how the use of an air-gap in an inductor increases the maximum saturating current and hence its operating range in DC/DC converters?

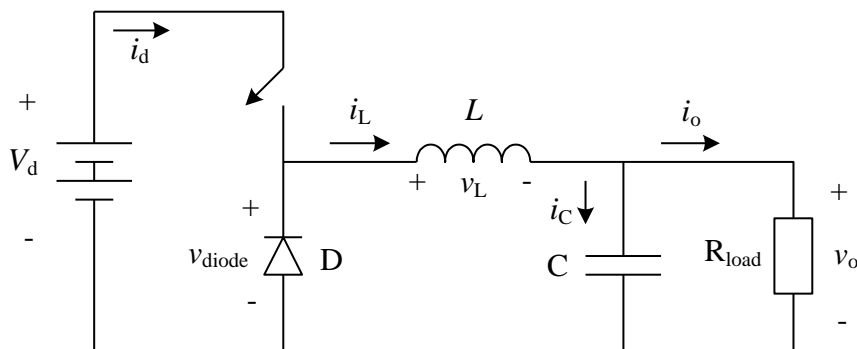
2) A step-down converter with ideal components shown below operates with an output voltage (V_o) of 12V and an output power (P_o) of 48W for an input voltage (V_d) of 20V and a switching frequency (f_{sw}) of 20 kHz. (8 points)

- Find the minimum inductance (L) for the converter to operate in continuous conduction mode (CCM).
- Calculate the inductance (L) in order to obtain the peak-to-peak current ripple in the inductor to be 10% of the average output current.
- Using the result in part (b), plot the inductor and capacitor current waveforms. Show the important points clearly.
- Using the capacitor current plotted in part (c), calculate the minimum capacitance (C) in order to limit the maximum peak-to-peak output voltage ripple to 1% of the average output voltage.

- 3) The flyback converter below has a protective winding (N_2) with the total turns ratio of the transformer given by $N_1:N_2:N_3 = 1:1:1$ and input voltage $V_d = 20V$. The switching frequency $f_{sw} = 20kHz$, the duty cycle $D = 0.3$ and the mutual inductance $L_m = 100\mu H$. For $R_{load} = 20\Omega$, calculate the average output voltage V_o and sketch the waveforms for v_{sw} , i_d and i_D . [Hint: you have to first decide if the converter is operating in continuous or discontinuous conduction mode] (6 points)

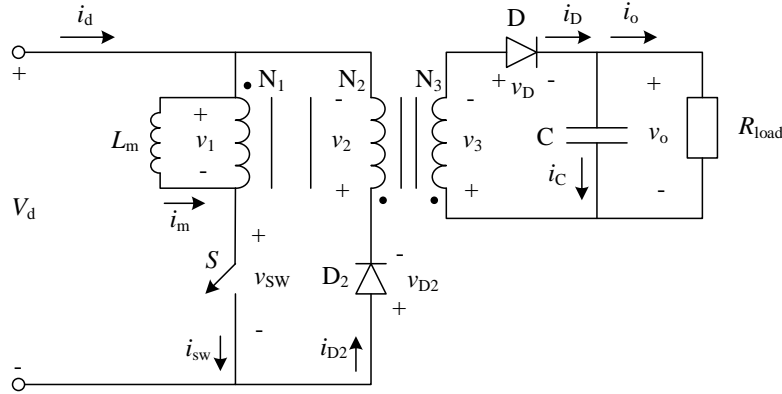

- 4) For a half-bridge DC/DC converter shown below operating in continuous conduction mode (CCM), (5 points)

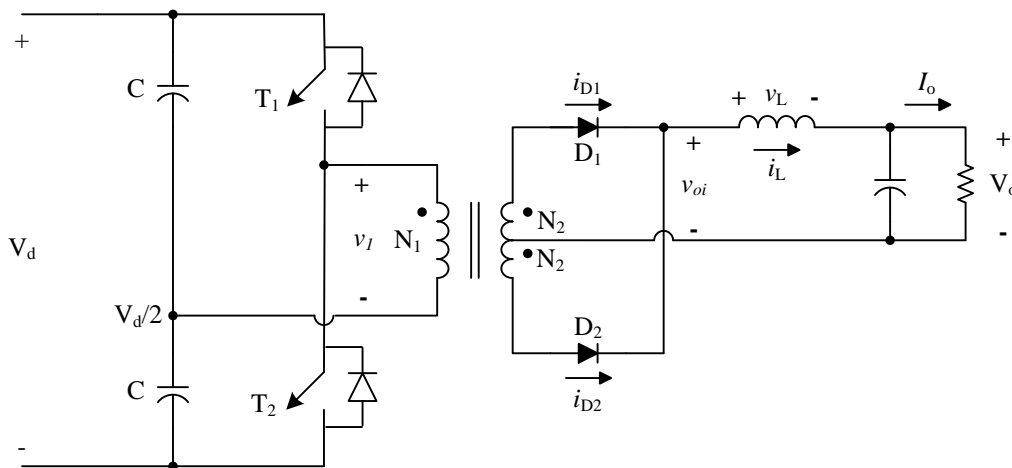

- Roughly sketch the waveforms for i_L , i_{D1} and i_{D2} for one switching cycle.
- Derive the expression for the output to input voltage ratio (V_o/V_d).
- What is the difference in the transformer used in a flyback and a half-bridge converter in terms of core magnetization?

5) For the single-phase inverter shown below with an input voltage $V_d = 300V$, (10 points)

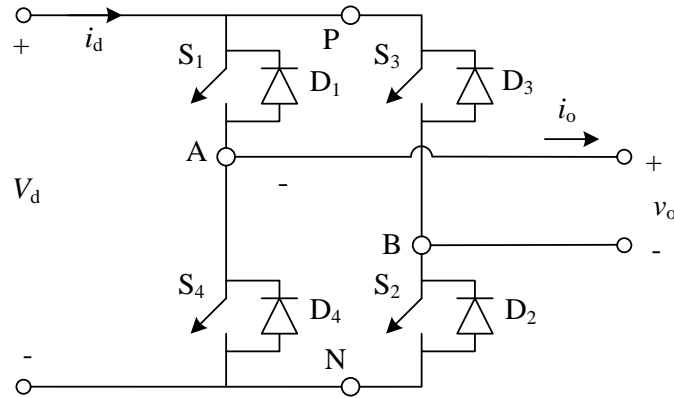

- (a) For a square-wave operation, plot the output voltage waveform and calculate the magnitude of the fundamental component.
- (b) Demonstrate a 4-quadrant operation of the inverter by indicating which switch or diode that is conducting when the output voltage and current are positive or negative.
- (c) For the inverter in PWM operation, calculate the magnitude of maximum fundamental voltage in the linear region (i.e., modulation index, $m_a \leq 1.0$).
- (d) What are the advantages and disadvantages of using a square-wave or a PWM operation?
- (e) If a 3-level neutral-point clamped (NPC) inverter is to be used instead of the 2-level inverter above, what are the advantages and disadvantages of the NPC inverter?

6) The three-phase diode rectifier shown below is used with a current-stiff load with $I_d = 20A$ and a negligible source inductance. The system operates with a 50Hz balanced 3-phase source with RMS Line-to-Line voltage of 400V. (6 points)

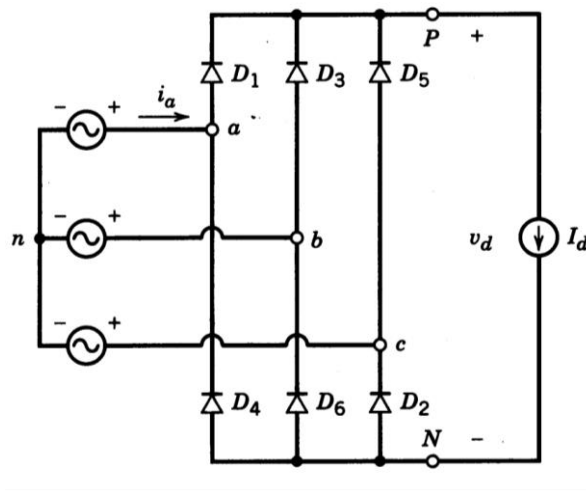

- (a) Plot the source voltage and current in phase a. what is the input displacement power factor (DPF)?
- (b) Plot the output voltage waveform and calculate its average value.
- (c) Explain the impact of source inductance on the average output voltage and the input DPF.

- 7) Consider the single-phase thyristor rectifier with a source inductance (L_s) of 5mH as shown below. The input is a square-wave shaped voltage with amplitude of 100V at a frequency of 50 Hz and the DC-side current (i_d) is constant at 10A. For a delay angle (α) of 30° , (5 points)

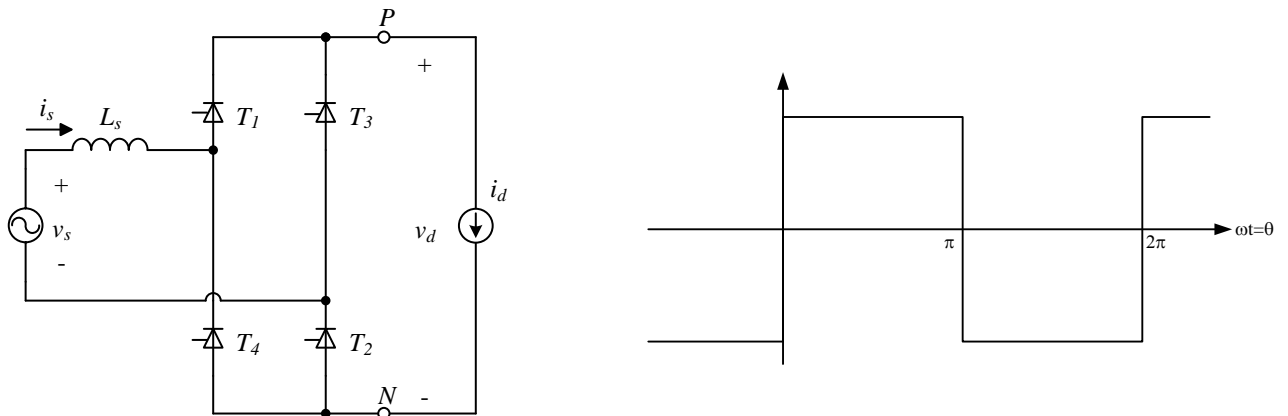

- (a) Plot the source current (i_s) and the output voltage waveform (v_d).
 (b) Calculate the average output voltage (V_d).
- 8) A MOSFET of type IRF 640N is exposed to a continuous power dissipation of 3 W. The ambient temperature is 25°C . Without any heat sink or forced cooling, the junction-to-ambient thermal resistance is 62°C/W . (4 points)
- (a) Motivate that a heat sink is needed.
 (b) With a heat sink used, calculate the maximum junction-to-ambient thermal resistance to limit the junction temperature of the MOSFET below 100°C .

Formula sheet for the Midterm exam of Power Electronic Converters (ENM061)

Fourier calculations

Table 3-1 Use of Symmetry in Fourier Analysis

Symmetry	Condition Required	a_h and b_h
Even	$f(-t) = f(t)$	$b_h = 0$ $a_h = \frac{2}{\pi} \int_0^{\pi} f(t) \cos(h\omega t) d(\omega t)$
Odd	$f(-t) = -f(t)$	$a_h = 0$ $b_h = \frac{2}{\pi} \int_0^{\pi} f(t) \sin(h\omega t) d(\omega t)$
Half-wave	$f(t) = -f(t + \frac{1}{2}T)$	$a_n = b_n = 0$ for even h $a_h = \frac{2}{\pi} \int_0^{\pi} f(t) \cos(h\omega t) d(\omega t)$ for odd h $b_h = \frac{2}{\pi} \int_0^{\pi} f(t) \sin(h\omega t) d(\omega t)$ for odd h
Even quarter-wave	Even and half-wave	$b_h = 0$ for all h $a_h = \begin{cases} \frac{4}{\pi} \int_0^{\pi/2} f(t) \cos(h\omega t) d(\omega t) & \text{for odd } h \\ 0 & \text{for even } h \end{cases}$
Odd quarter-wave	Odd and half-wave	$a_h = 0$ for all h $b_h = \begin{cases} \frac{4}{\pi} \int_0^{\pi/2} f(t) \sin(h\omega t) d(\omega t) & \text{for odd } h \\ 0 & \text{for even } h \end{cases}$

Definition of RMS-value:

$$F_{RMS} = \sqrt{\frac{1}{T} \int_{t_0}^{t_0+T} f(t)^2 dt}$$

Definition of RMS-value with Fourier-series:

$$F_{RMS} = \sqrt{F_0^2 + \sum_{n=1}^{\infty} F_n^2} = \sqrt{\left(\frac{a_0}{2}\right)^2 + \sum_{n=1}^{\infty} \left(\frac{\sqrt{a_n^2 + b_n^2}}{\sqrt{2}}\right)^2}$$

Trigonometry

$$\sin^2(\alpha) + \cos^2(\alpha) = 1$$

$$\sin(\alpha + \beta) = \sin(\alpha) \cos(\beta) + \cos(\alpha) \sin(\beta)$$

$$\cos(\alpha + \beta) = \cos(\alpha) \cos(\beta) - \sin(\alpha) \sin(\beta)$$

$$\sin(\alpha) \sin(\beta) = \frac{1}{2} (\cos(\alpha - \beta) - \cos(\alpha + \beta))$$

$$\cos(\alpha) \cos(\beta) = \frac{1}{2} (\cos(\alpha - \beta) + \cos(\alpha + \beta))$$

$$\int \sin(ax) dx = -\frac{1}{a} \cos(ax), \quad \int x \sin(ax) dx = \frac{1}{a^2} (\sin(ax) - ax \cos(ax)), \quad \int \cos(ax) dx = \frac{1}{a} \sin(ax)$$

$$\int x \cos(ax) dx = \frac{1}{a^2} (\cos(ax) + ax \sin(ax))$$

$$\sin(\alpha - \beta) = \sin(\alpha) \cos(\beta) - \cos(\alpha) \sin(\beta)$$

$$\cos(\alpha - \beta) = \cos(\alpha) \cos(\beta) + \sin(\alpha) \sin(\beta)$$

$$\sin(\alpha) \cos(\beta) = \frac{1}{2} (\sin(\alpha - \beta) + \sin(\alpha + \beta))$$

$$PF = \frac{P}{S} = \frac{V_s I_{s1} \cos \phi_1}{V_s I_s}, \quad DPF = \cos \phi_1, \quad \%THD_i = 100 \frac{I_{dis}}{I_{s1}} = 100 \frac{\sqrt{I_s^2 - I_{s1}^2}}{I_{s1}} = 100 \sqrt{\sum_{h \neq 1} \left(\frac{I_{sh}}{I_{s1}}\right)^2}$$

Electromagnetics

$$e = \frac{d}{dt} \psi \quad \psi = N\phi \quad \phi = BA \quad R = \frac{l}{A\mu_r\mu_0} \quad L = \frac{\Psi}{i}$$

$$NI = R\phi = mmf \quad N\phi = LI \quad L = N^2/R \quad W = \frac{1}{2} Li^2$$

Capacitor and inductor current-voltage relationship

$$i_C = C \frac{dv_C}{dt} \quad v_L = L \frac{di_L}{dt}$$