

Midterm Exam ENM061 Power Electronic Converters

Monday November 21, 2016

Lecturer/Tutor: Mebtu Beza/Andreas Andersson

Help: CTH approved calculator (Casio FX82, Texas TI30, Sharp EL531)

The bonus points are awarded as follows.

- 0: 0 – 9 pts.
 - 2: 10 – 19 pts.
 - 4: 20 – 25 pts.
-

1. Briefly answer the following questions.(4 points)

- (a) What is the difference between a diode and a thyristor?
- (b) What is the difference in application between a MOSFET and an IGBT?
- (c) What does an equivalent-series-resistance (ESR) of a capacitor represent and why is it important?
- (d) Explain the purpose of using isolation transformer in power electronic converters.

2. For a step-down converter with ideal components shown below, a constant output voltage (V_o) of 8V is achieved by controlling the duty cycle D . The input voltage (V_d) is 20V, the switching frequency (f_{sw}) is 20 kHz, the inductance (L) is 100 μ H, the capacitance (C) is 500 μ F and the output power is 50W. (6 points)

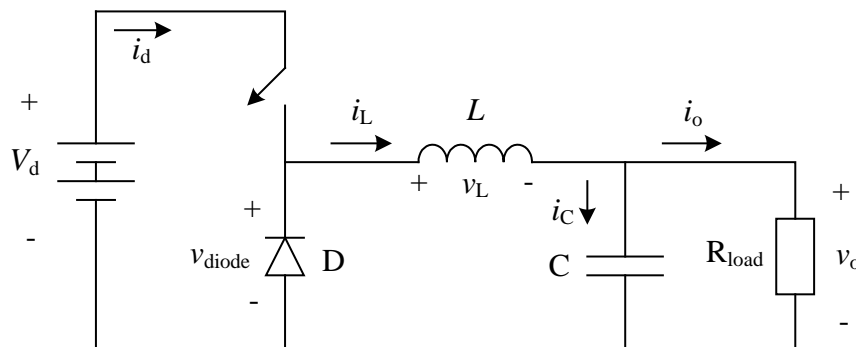

- (a) Show that the converter is operating in CCM and calculate the duty cycle, D .
- (b) Calculate the average output and input currents, I_o and I_d .
- (c) Plot the capacitor current $i_C(t)$ and using the current plot calculate the output voltage ripple, Δv_o .

3. For a boost converter shown below and operating in CCM mode, derive the expression of the output voltage to input voltage ratio (V_o/V_d). Plot the ratio (V_o/V_d) as a function of the duty cycle (D) for the ideal and practical converter and explain the difference. (3 points)

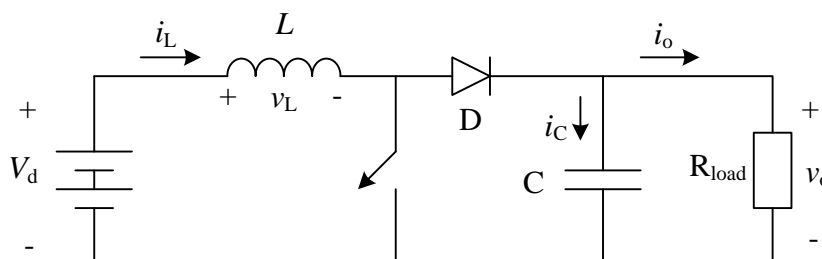

4. The flyback converter below has a protective winding (N_2) with the total turns ratio of the transformer given by $N_1:N_2:N_3 = 1:1:2$. (6 points)

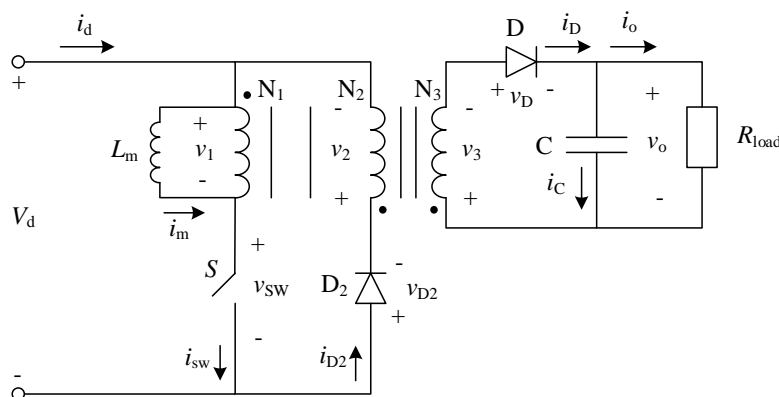

- (a) For DCM operation with no current in winding N_2 , derive the relationship between the output and input voltage (in terms of switching frequency f_{sw} , duty cycle D , mutual inductance L_m and load resistance R_{load}).
- (b) For DCM operation and no current in winding N_2 , roughly sketch the waveforms for v_1 , i_m , i_d and i_D .
- (c) Explain briefly how the winding N_2 limits the maximum output voltage for high value of R_{load} .

5. The full-bridge DC/DC converter shown below uses a PWM bipolar voltage switching (i.e., When $v_{control} \geq v_{tri}$, $S1$ & $S3$ are on and $S2$ & $S4$ are off. When $v_{control} < v_{tri}$, $S2$ & $S4$ are on and $S1$ & $S3$ are off). For $\hat{V}_{tri} = V_d = 20V$, $v_{control} = 10V$ and $i_o = I_o = 5A$, (6 points)

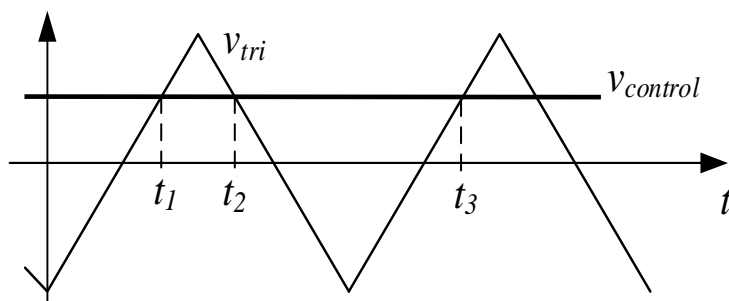
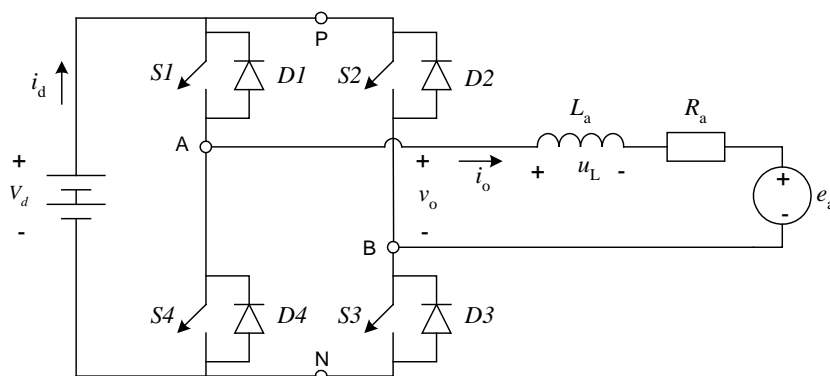

- (a) Plot the output voltage waveform v_o and input current waveform i_d for $t_1 \leq t \leq t_3$.
- (b) Calculate the average output voltage V_o and the average input current I_d .
- (c) Which active components are conducting for the interval $t_1 \leq t \leq t_2$ and $t_2 \leq t \leq t_3$.

Formula sheet for the Midterm exam of Power Electronic Converters (ENM061)

Fourier calculations

Table 3-1 Use of Symmetry in Fourier Analysis

Symmetry	Condition Required	a_h and b_h
Even	$f(-t) = f(t)$	$b_h = 0$ $a_h = \frac{2}{\pi} \int_0^{\pi} f(t) \cos(h\omega t) d(\omega t)$
Odd	$f(-t) = -f(t)$	$a_h = 0$ $b_h = \frac{2}{\pi} \int_0^{\pi} f(t) \sin(h\omega t) d(\omega t)$
Half-wave	$f(t) = -f(t + \frac{1}{2}T)$	$a_h = b_h = 0$ for even h $a_h = \frac{2}{\pi} \int_0^{\pi} f(t) \cos(h\omega t) d(\omega t)$ for odd h $b_h = \frac{2}{\pi} \int_0^{\pi} f(t) \sin(h\omega t) d(\omega t)$ for odd h
Even quarter-wave	Even and half-wave	$b_h = 0$ for all h $a_h = \begin{cases} \frac{4}{\pi} \int_0^{\pi/2} f(t) \cos(h\omega t) d(\omega t) & \text{for odd } h \\ 0 & \text{for even } h \end{cases}$
Odd quarter-wave	Odd and half-wave	$a_h = 0$ for all h $b_h = \begin{cases} \frac{4}{\pi} \int_0^{\pi/2} f(t) \sin(h\omega t) d(\omega t) & \text{for odd } h \\ 0 & \text{for even } h \end{cases}$

Definition of RMS-value:

$$F_{RMS} = \sqrt{\frac{1}{T} \int_{t_0}^{t_0+T} f(t)^2 dt}$$

Definition of RMS-value with Fourier-series:

$$F_{RMS} = \sqrt{F_0^2 + \sum_{n=1}^{\infty} F_n^2} = \sqrt{\left(\frac{a_0}{2}\right)^2 + \sum_{n=1}^{\infty} \left(\frac{\sqrt{a_n^2 + b_n^2}}{\sqrt{2}}\right)^2}$$

Trigonometry

$$\sin^2(\alpha) + \cos^2(\alpha) = 1$$

$$\sin(\alpha + \beta) = \sin(\alpha) \cos(\beta) + \cos(\alpha) \sin(\beta)$$

$$\cos(\alpha + \beta) = \cos(\alpha) \cos(\beta) - \sin(\alpha) \sin(\beta)$$

$$\sin(\alpha) \sin(\beta) = \frac{1}{2} (\cos(\alpha - \beta) - \cos(\alpha + \beta))$$

$$\cos(\alpha) \cos(\beta) = \frac{1}{2} (\cos(\alpha - \beta) + \cos(\alpha + \beta))$$

$$\int \sin(ax) dx = -\frac{1}{a} \cos(ax), \int x \sin(ax) dx = \frac{1}{a^2} (\sin(ax) - ax \cos(ax)), \int \cos(ax) dx = \frac{1}{a} \sin(ax)$$

$$\int x \cos(ax) dx = \frac{1}{a^2} (\cos(ax) + ax \sin(ax))$$

$$\sin(\alpha - \beta) = \sin(\alpha) \cos(\beta) - \cos(\alpha) \sin(\beta)$$

$$\cos(\alpha - \beta) = \cos(\alpha) \cos(\beta) + \sin(\alpha) \sin(\beta)$$

$$\sin(\alpha) \cos(\beta) = \frac{1}{2} (\sin(\alpha - \beta) + \sin(\alpha + \beta))$$

$$PF = \frac{P}{S} = \frac{V_s I_{s1} \cos \phi_1}{V_s I_s}, DPF = \cos \phi_1, \%THD_i = 100 \frac{I_{dis}}{I_{s1}} = 100 \frac{\sqrt{I_s^2 - I_{s1}^2}}{I_{s1}} = 100 \sqrt{\sum_{h \neq 1} \left(\frac{I_{sh}}{I_{s1}}\right)^2}$$

Electromagnetics

$$e = \frac{d}{dt} \psi \quad \psi = N\phi \quad \phi = BA \quad R = \frac{l}{A\mu_r\mu_0} \quad L = \frac{\Psi}{i}$$

$$NI = R\phi = mmf \quad N\phi = LI \quad L = N^2/R \quad W = \frac{1}{2} Li^2$$

Capacitor and inductor current-voltage relationship

$$i_C = C \frac{dv_C}{dt} \quad v_L = L \frac{di_L}{dt}$$