

Examination**ENM060 Power Electronic Converters****Date and time**Monday January 11th, 2016, 14:00 – 18:00**Responsible Teacher:**

Andreas Henriksson, tel. 0709-524924

Authorised Aids:

Chalmers-approved calculator (Casio FX82..., Texas Instruments Ti-30... and Sharp EL-W531...)

Grades:

U, 3, 4 or 5. (The limit for a 3 on the exam is 20p, a 4 is 30p and 5 is 40p. The maximum number of points is 50.)

Solutions:Course webpage (Ping-Pong), January 12th 2016**Review of Exam**February 9th and February 17th, 12:00-13:00.Fredrik Lamms Room. Division of Electric Power Engineering (1st floor).From February 18th 2016, the exams can be picked-up at the exam office, Department of Energy and Environment.

Location: EDIT building, Maskingränd 2, 3Ö (east) floor, room 3434A.

Opening hours during semesters: Monday-Friday 12:30-14:30

Observe that the questions are not arranged in any kind of order.

On the last pages there are some formulas that can be used in the examination. Always assume steady-state conditions in all tasks unless otherwise stated.

Please, read through the exam before you start.

- 1) For the circuit below with $T = 30\mu\text{s}$ and $D = 0.6$, sketch the resulting voltage and calculate the inductance needed if the voltage applied over the inductor during $DT < t < T$ is 24V . (3p)

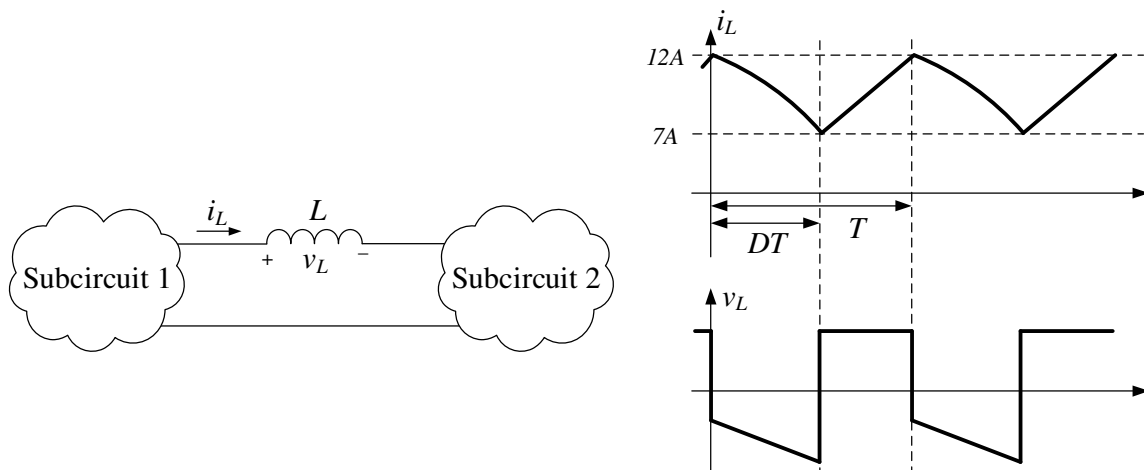

The constant inductor voltage during $DT < t < T$ is given. The resulting current through the inductor can be calculated as:

$$i_L = i_L(t_1) + \frac{1}{L} \int v_L dt$$

Which means that the current derivative will be positive when the applied voltage is positive.

$$L = \frac{\text{VoltSeconds}}{\Delta i_L} = \frac{0.4 \cdot 30\mu\text{s} \cdot 24\text{V}}{5\text{A}} = 57.6\mu\text{H}$$

- 2) For the buck converter below, derive an expression for the ratio between the input and the output voltage if the converter is operating in CCM. (2p)

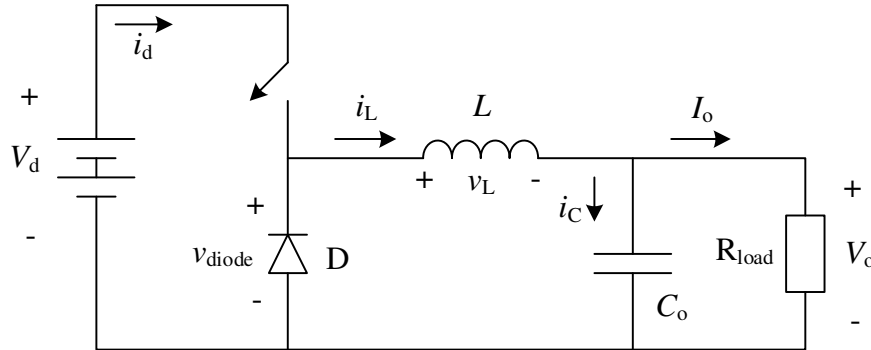

The average inductor voltage over one switching period is equal to zero when operating in steady state which gives:

$$V_L = \frac{1}{T_s} \left(\int_0^{DT_s} (V_d - V_o) dt + \int_{DT_s}^{T_s} (-V_o) dt \right) = \frac{1}{T_s} (V_d DT_s - V_o DT_s - V_o T_s + V_o DT_s) = 0$$

$$V_o = V_d D \rightarrow D = \frac{V_o}{V_d}$$

- 3) The buck converter in (2) is used with the circuit parameters and operating conditions below. Apply Simpsons formula and calculate the maximum power dissipation in the diode if $V_F = 0.63\text{V}$ is used. (5p)

$$20\text{V} \leq V_d \leq 40\text{V} \quad V_o = 12\text{V} \quad L = 40\mu\text{H} \quad f_s = 80\text{kHz} \quad C_o = 330\mu\text{F} \quad I_o = 7\text{A}$$

The input voltage can vary which gives a duty-cycle that also varies.

$$D = \frac{V_o}{V_d} \rightarrow D_1 = \frac{12\text{V}}{20\text{V}} = 0.6 \quad \rightarrow \quad D_2 = \frac{12\text{V}}{40\text{V}} = 0.3$$

The average output current equals the average inductor current.

$$I_o = I_L = 7\text{A}$$

The peak-to-peak ripple in the inductor current can be calculated. During the period $0 \leq t \leq DT_{sw}$ is the inductor voltage constant and equal to the input voltage. The equation can then be written as:

$$v_L = L \frac{di_L}{dt} = L \frac{\Delta i_L}{\Delta t} \rightarrow \begin{aligned} \Delta i_{L(1)} &= \frac{(V_d - V_o)DT_s}{L} = \frac{(20\text{V} - 12\text{V}) \cdot 0.6}{40\mu\text{H} \cdot 80\text{kHz}} = 1.50\text{A} \\ \Delta i_{L(2)} &= \frac{(V_d - V_o)DT_s}{L} = \frac{(40\text{V} - 12\text{V}) \cdot 0.3}{40\mu\text{H} \cdot 80\text{kHz}} = 2.62\text{A} \end{aligned}$$

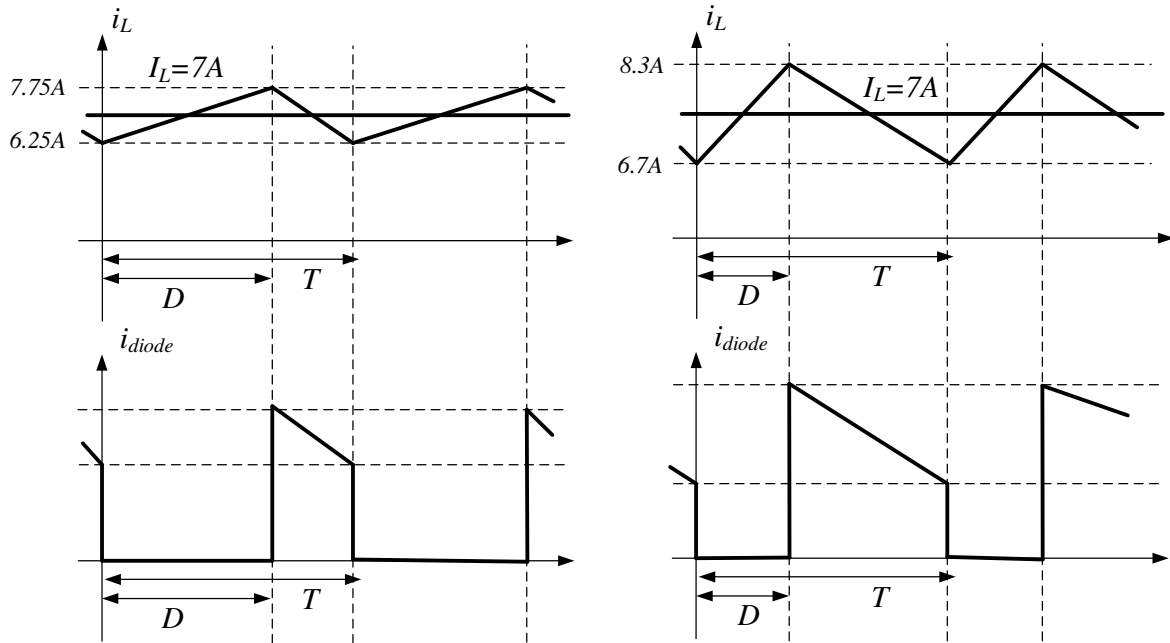

To calculate the power loss in the diode, only the constant voltage drop is accounted for, this gives a need to calculate the average current through the diode. The definition for Simpsons rule is:

$$\frac{1}{T} \int_{t_0}^{t_0+T} f(x) dx = \frac{1}{6} \left(f(t_0) + 4 \cdot f\left(t_0 + \frac{T}{2}\right) + f(t_0 + T) \right)$$

The AVG current can now be calculated as:

$$I_{D(AVG)(1)} = \frac{1}{12.5\mu} \left(\frac{7.5\mu}{7.5\mu} \int_0^{7.5\mu} 0 dt + \frac{5\mu}{5\mu} \int_{7.5\mu}^{12.5\mu} i_D(t) dt \right) = \frac{5\mu}{12.5\mu} \frac{1}{6} ((7.75) + 4(7A) + (6.25A)) = 2.8A$$

$$I_{D(AVG)} = \frac{1}{12.5\mu} \left(\frac{3.75\mu}{3.75\mu} \int_0^{3.75\mu} 0 dt + \frac{8.75\mu}{8.75\mu} \int_{3.75\mu}^{12.5\mu} i_D(t) dt \right) = \frac{8.75\mu}{12.5\mu} \frac{1}{6} ((8.3A) + 4(7A) + (6.7A)) = 5.0A$$

- 4) For the flyback converter below, an LC-filter is applied to the input that smoothens the current drawn from the DC-source. Calculate the power dissipation in the input filter capacitor if $R_{ESR} = 80m\Omega$. Assume that the input filter is sufficiently large so that the current from the DC-source is a pure DC-current. (5p)

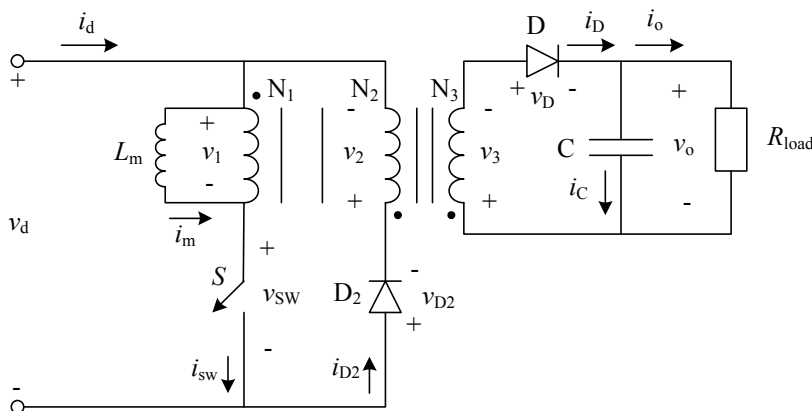

The turns ratio was missing on the exam. Points are given for reasonable assumptions.

$$L_m = 63\mu H \quad C = 470\mu F \quad V_d = 9V \quad V_o = 24V \quad f_{sw} = 100kHz \quad I_o = 2.5A$$

$$(N_1 : N_2 : N_3) = (4 : 1 : 4)$$

The ratio between the input and output voltage is:

$$V_L = \frac{1}{T_{sw}} \int_0^{DT_{sw}} V_d dt + \frac{1}{T_{sw}} \int_{DT_{sw}}^{T_{sw}} -V_o dt = \frac{1}{T_{sw}} (V_d DT_{sw} - V_o T_{sw} + V_o DT_{sw}) = 0$$

Since the output voltage is held constant at 24V, the switch duty ratio D can be calculated:

$$V_d D = V_o(1 - D) \rightarrow \frac{V_o}{V_d} = \frac{D}{1 - D} \rightarrow \frac{24V}{9V} = \frac{D}{1 - D} \rightarrow D = 0.727$$

During the on-time of the switch, the inductor voltage is constant ($v_L = V_d$) which gives

$$v_L = L \frac{\Delta i_L}{\Delta t} \rightarrow \Delta i_L = \frac{v_L \Delta t}{L} = \frac{V_d D}{f_{sw} L} = \frac{9V}{63\mu H} \cdot \frac{0.727}{100kHz} = 1.04A$$

The average input current is calculated as:

$$P_o = P_d \rightarrow V_o I_o = V_d I_d \rightarrow I_o = \frac{V_d I_d}{V_o} = \frac{I_d V_o (1 - D)}{V_o} \rightarrow \frac{I_o}{I_d} = \frac{(1 - D)}{D} \rightarrow I_d = \frac{D I_o}{(1 - D)} = \frac{0.727 \cdot 2.5A}{(1 - 0.727)} = 6.66A$$

$$I_o = I_m(1 - D) \rightarrow I_m = \frac{2.5A}{1 - 0.727} = 9.16A$$

CCM is valid since $I_L > (\Delta i_L / 2 = 0.52A)$.

Since the input filter is well dimensioned, the current drawn from the DC-source can be considered a purely DC-current. If a pure DC-current is flowing from the DC-source, the entire ripple current must flow through the capacitor. The rms-value of the capacitor current can be calculated according to the definition

$$I_{C(RMS)} = \sqrt{\frac{1}{10\mu} \int_0^{10\mu} i_c^2(t) dt =}$$

The definition for Simpsons rule is:

$$\frac{1}{T} \int_{t_0}^{t_0+T} f(x) dx = \frac{1}{6} \left(f(t_0) + 4 \cdot f\left(t_0 + \frac{T}{2}\right) + f(t_0 + T) \right)$$

The RMS-current can now be calculated as:

$$I_{C(RMS)} = \sqrt{\frac{1}{10\mu} \left(7.27\mu \frac{1}{7.27\mu} \int_0^{7.27\mu} i_c^2(t) dt + 2.73\mu \frac{1}{2.73\mu} \int_{7.27\mu}^{10\mu} i_c^2(t) dt \right) =}$$

$$= \sqrt{\frac{7.27\mu}{10\mu} \frac{1}{6} \left(\left(9.16A - \frac{1.04A}{2} - 6.66A \right)^2 + 4 \left(9.16A - 6.66A \right)^2 + \left(9.16A + \frac{1.04A}{2} - 6.66A \right)^2 \right) + \frac{2.73\mu}{10\mu} (6.66A)^2}$$

$$= 4.08A$$

The power dissipation in the capacitor can now be calculated as:

$$P_C = R_{ESR} I_{C(RMS)}^2 = 80m\Omega \cdot 4.08A^2 = 1.33W$$

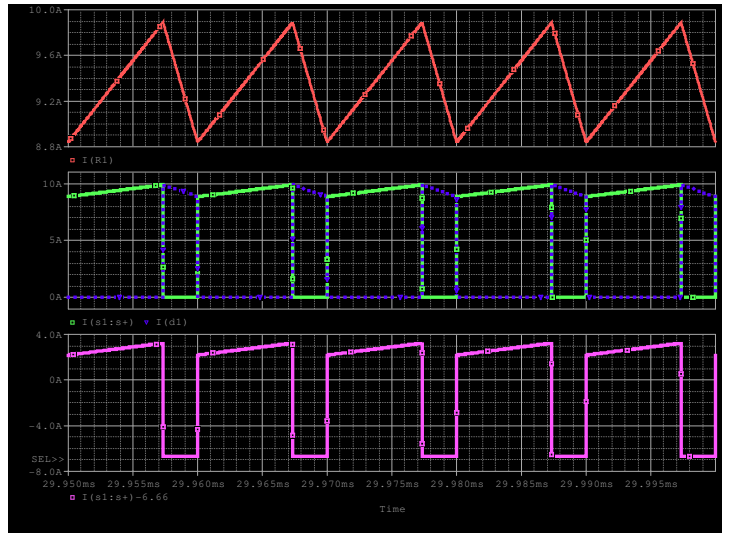

- 5) **You shall design a transformer and you have two different RM6R-cores made of material 3D3 to choose between; a core with 0.7mm airgap and a core without airgap (see datasheet below). For the two cores, calculate the maximum allowed current with and without an airgap for $B_{max} = 380mT$. Also, exemplify for which converter topologies transformers with and without airgaps can be used. (4p)**

CORE SETS

Effective core parameters

SYMBOL	PARAMETER	VALUE	UNIT
$\Sigma(l/A)$	core factor (C1)	0.810	mm ⁻¹
V_e	effective volume	810	mm ³
l_e	effective length	25.6	mm
A_e	effective area	32.0	mm ²
A_{min}	minimum area	23.8	mm ²
m	mass of set	= 4.5	g

N=33

The number of turns was missing on the exam. Points are given for reasonable assumptions or for expressing it as $A \cdot \text{turns}$.

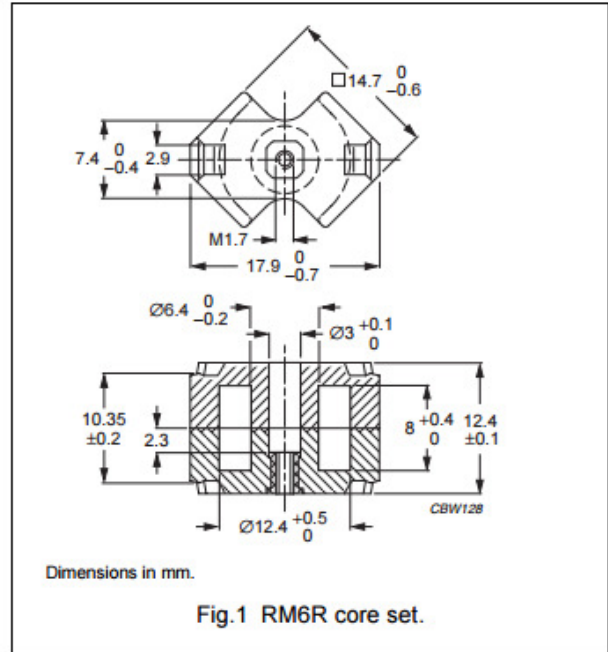

Core sets for filter applications

Clamping force for A_L measurements, 40 ±20 N.

GRADE	A_L (nH)	μ_e	TOTAL AIR GAP (μm)	TYPE NUMBER (WITH NUT)	TYPE NUMBER (WITHOUT NUT)
3D3 ^{sup}	40 ±3%	= 26	= 1200	RM6R-3D3-E40/N	RM6R-3D3-E40
	63 ±3%	= 41	= 700	RM6R-3D3-E63/N	RM6R-3D3-E63
	100 ±3%	= 65	= 400	RM6R-3D3-E100/N	RM6R-3D3-E100
	160 ±3%	= 103	= 200	RM6R-3D3-A160/N	RM6R-3D3-A160
	1000 ±25%	= 650	= 0	-	RM6R-3D3

If the air gap is considered, the majority of the reluctance lies within the air gap, hence can the core be neglected in this case. The inductance for each transformer can be calculated as:

$$L = \frac{N^2}{\mathfrak{R}} = \begin{cases} L_{ungapped} = \frac{33^2}{l_e / \mu_r \mu_0 A_e} = \frac{33^2}{25.6 \text{ mm} / 650 \cdot 4\pi e^{-7} \cdot 32 \text{ mm}^2} = 1111 \mu\text{H} \\ L_{gapped(1)} = \frac{33^2}{l_g / \mu_0 A_e} = \frac{33^2}{0.7 \text{ mm} / 4\pi e^{-7} \cdot 32 \text{ mm}^2} = 62 \mu\text{H} \\ L_{gapped(2)} = \frac{33^2}{l_g / \mu_0 A_e} = \frac{33^2}{25.6 \text{ mm} / 41 \cdot 4\pi e^{-7} \cdot 32 \text{ mm}^2} = 70 \mu\text{H} \end{cases}$$

$$I_{sat} = \frac{B_{max} A_e}{N} (\mathfrak{R}_g + \mathfrak{R}_c) = \begin{cases} I_{sat(ungapped)} = \frac{380 \text{ mT} \cdot 32 \text{ mm}^2}{33} \frac{25.6 \text{ mm}}{650 \cdot 4\pi e^{-7} \cdot 32 \text{ mm}^2} = 0.36 \text{ A} \\ I_{sat(gapped,1)} = \frac{380 \text{ mT} \cdot 32 \text{ mm}^2}{33} \frac{0.7 \text{ mm}}{4\pi e^{-7} \cdot 32 \text{ mm}^2} = 6.41 \text{ A} \\ I_{sat(gapped,2)} = \frac{380 \text{ mT} \cdot 32 \text{ mm}^2}{33} \frac{25.6 \text{ mm}}{41 \cdot 4\pi e^{-7} \cdot 32 \text{ mm}^2} = 5.72 \text{ A} \end{cases}$$

Gapped core is suitable for a Flyback converter. The transformer in the flyback converter is used as an energy storage device which means that an air gap is preferred. A flyback transformer doesn't have the ampere-turn cancellation benefit of a forward converter, so the entire energy storage in the core moves the core up its hysteresis curve. The air gap flattens the hysteresis curve and allows more energy handling by decreasing the permeability of the core. You will of course need to add more turns to get your desired inductance compared to no-gap, but you avoid core saturation.

Ungapped core is more suitable in e.g. a forward converter where the magnetizing inductance shall be kept as large as possible in order to minimize the current ripple.

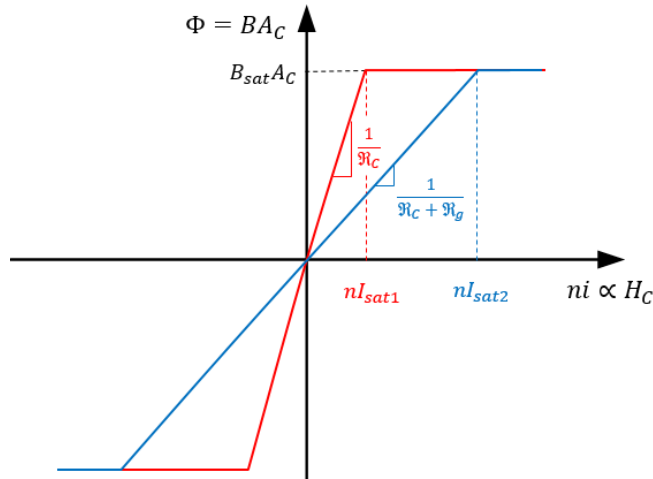

- 6) The three phase diode rectifier depicted below is used with a voltage stiff DC-link and a negligible source inductance. The system operates with 50Hz and $v_a = v_b = v_c = 230V$ peak voltage. Draw the phase voltage in phase a (v_{an}), the resulting line-to-line voltage between phases a , b and c (v_{ab} and v_{ac}) and the phase current (i_a). Clearly state the amplitudes and phase shifts between the voltages. An exact value of the line current is not needed. (4p)

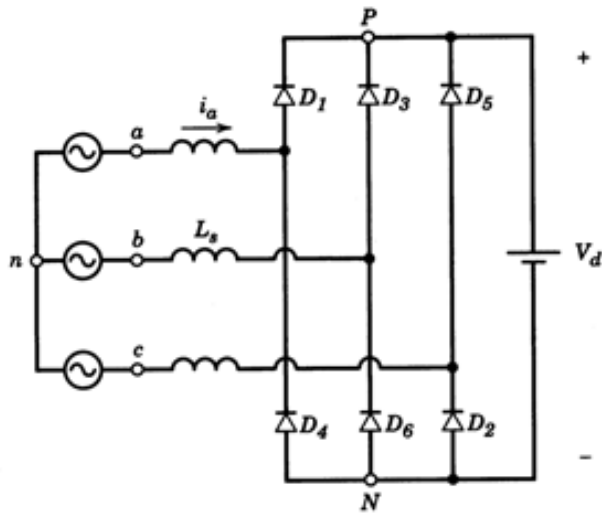

Current is drawn from the voltage source as long as the input voltage is higher than the output voltage. Note that this happens two times for each phase, when the line-to-line voltages (v_{ab} and v_{ac}) are higher than the output voltage, a current is drawn from the source. This can be seen as two pulses in the middle of the a -phase voltage.

Points are given if the answer shows a difference in amplitude and phase (30°) between the phase and line-to-line voltages. To score full points, the correct phase current has to be drawn.

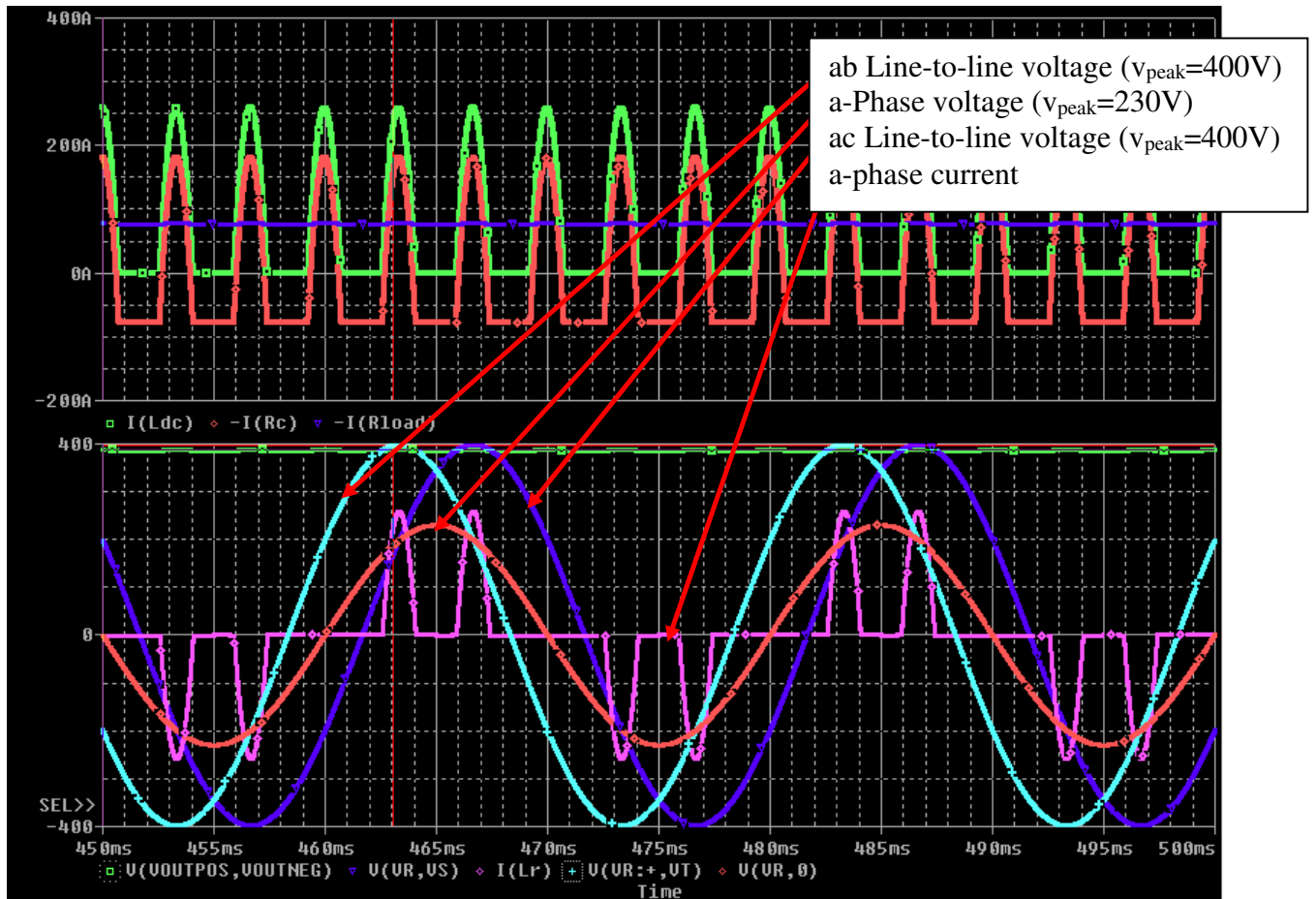

7) The diode rectifier in (7) is now connected to a grid with a source inductance. How will this affect the power factor (PF) and the displacement power factor (DPF)? Exemplify with e.g. graphs and Fourier components. (3p)

If the source inductance is taken into account, the current waveforms will be smoothed out due to the inductance. As the source inductance continues to increase, the DC-side current will eventually become continuous.

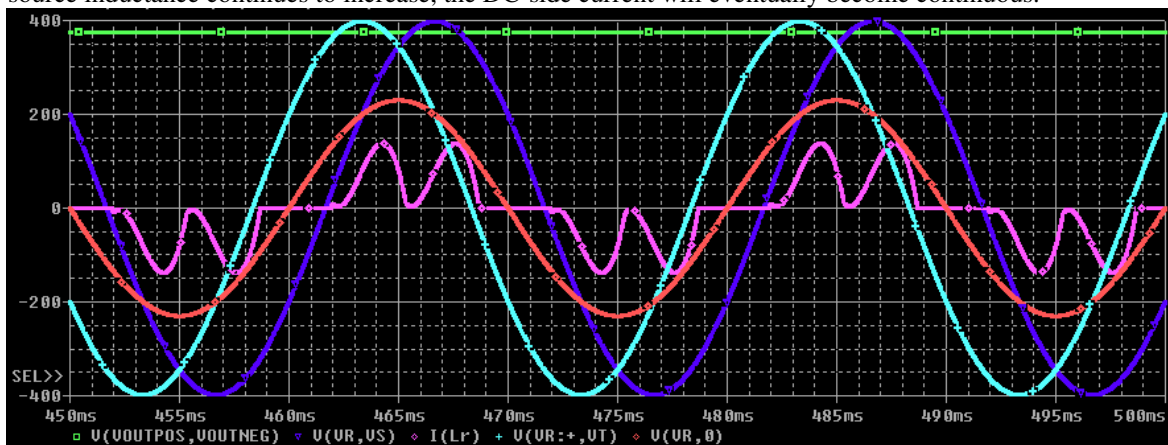

Unlike for the single phase diode rectifier with a source inductance, the fundamental frequency component of the line current will not change significantly (compare Figure 5-18 and 5-37 in Undeland) if the source inductance is increased. The power factor will increase since the harmonics will decrease as the source inductance increases.

8) The single phase inverter below. Determine the 3 first harmonic components of the load voltage for square-wave operation. (4p)

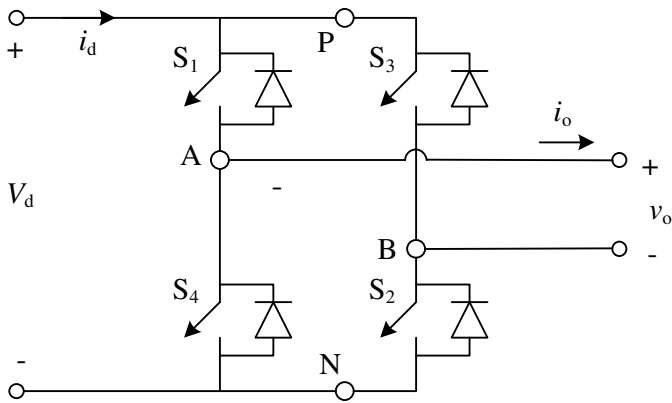

Nominal values for square wave inverter

Source voltage	$U_s = 200V$
Load inductance	$L = 10mH$
Load resistance	$R = 2\Omega$
Fundamental frequency	$f_{s,1} = 50Hz$

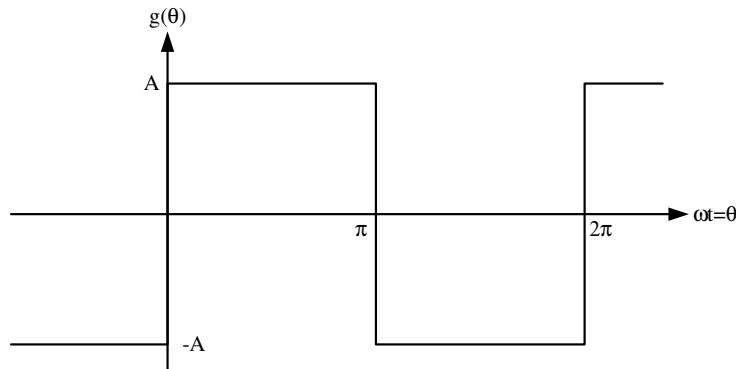

From the figure we see that $g(\theta)$ is odd, $g(\theta) = -g(-\theta)$, and half-wave, $g(\theta) = g(\theta + \pi) \Rightarrow$

$$a_n = 0 \quad \text{for all } n$$

$$b_n = \frac{4}{\pi} \int_{\theta_0}^{\theta_0 + \pi/2} g(\theta) \sin(n\theta) d\theta \quad \text{for } n=1,3,5,\dots \text{ (odd)}$$

$$b_n = 0 \quad \text{for } n=2,4,6,\dots \text{ (even)}$$

for odd n

$$b_n = \frac{4}{\pi} \int_0^{\pi/2} A \sin(n\theta) d\theta = -\frac{4}{\pi} \frac{A}{n} [\cos(n\theta)]_0^{\pi/2} = \frac{4}{\pi} \frac{A}{n} (1 - \underbrace{\cos(n \frac{\pi}{2})}_{=0 \text{ for odd } n}) = \frac{4}{\pi} \frac{A}{n}$$

The average of the function is zero since a_0 is zero.

$$b_{n,rms} = \frac{b_n}{\sqrt{2}} = \frac{2\sqrt{2}}{\pi} \frac{A}{n} \quad \text{for } n=1,3,5,\dots \text{ (odd)}$$

Frequency	$u_{o(n)}$ calculated (RMS)
50Hz (n=1)	180V
100 Hz (n=2)	0
150 Hz (n=3)	60V
200 Hz (n=4)	0
250 Hz (n=5)	36V

- 9) If the single phase inverter in (8) is operated with PWM bipolar switching in the linear range ($m_a \leq 1$). What is the lowest DC-link voltage that is required in order to obtain a fundamental frequency voltage component of 180V_{RMS}? (2p)

The fundamental frequency voltage component can be adjusted by changing the modulation index. The highest value is obtained when $m_a=1$.

$$V_{o(1)RMS} = \frac{V_d m_a}{\sqrt{2}} \rightarrow V_d = \frac{V_{o(1)RMS} \sqrt{2}}{m_a} = \frac{180V \cdot \sqrt{2}}{1} = 254V$$

10) The single phase inverter in (8) is operated in PWM-mode with unipolar switching. For the shaded time interval (the fundamental frequency component of the output voltage is positive and the output current is negative), draw the current paths in the circuit and clearly mark which components (e.g. switches or diodes) that carry the current. (3p)

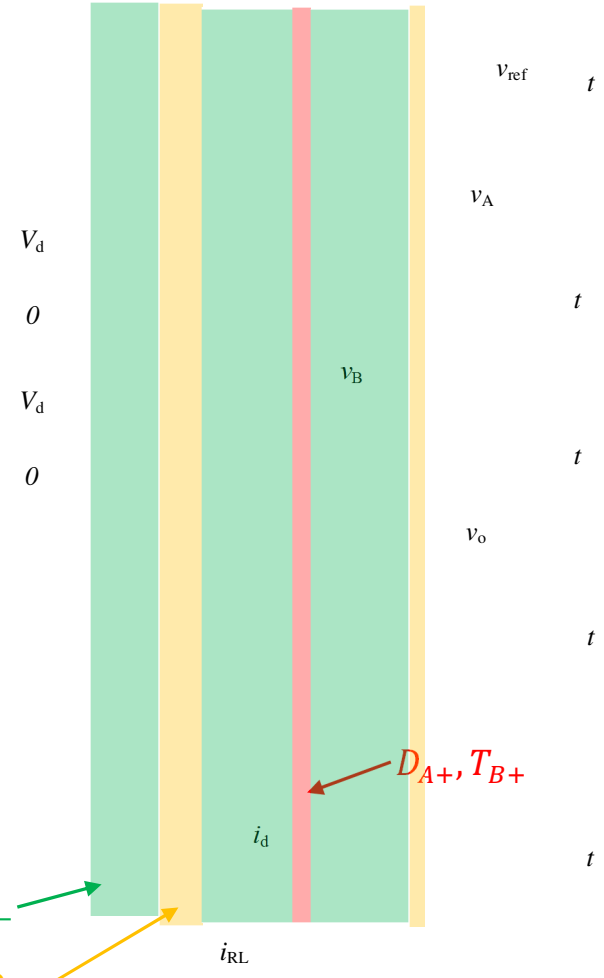
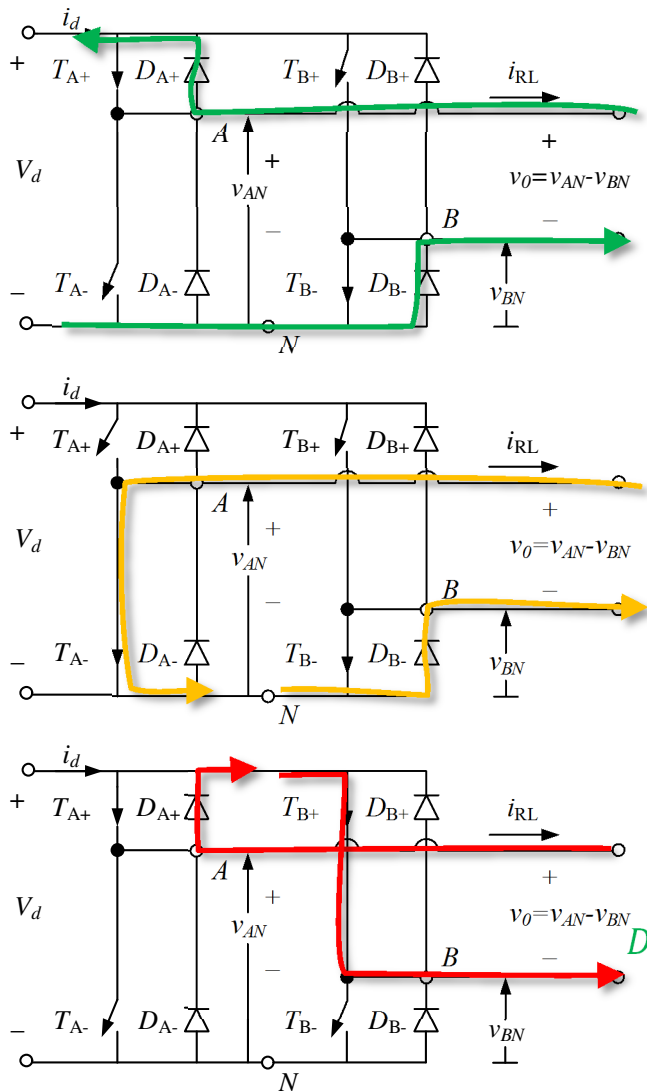
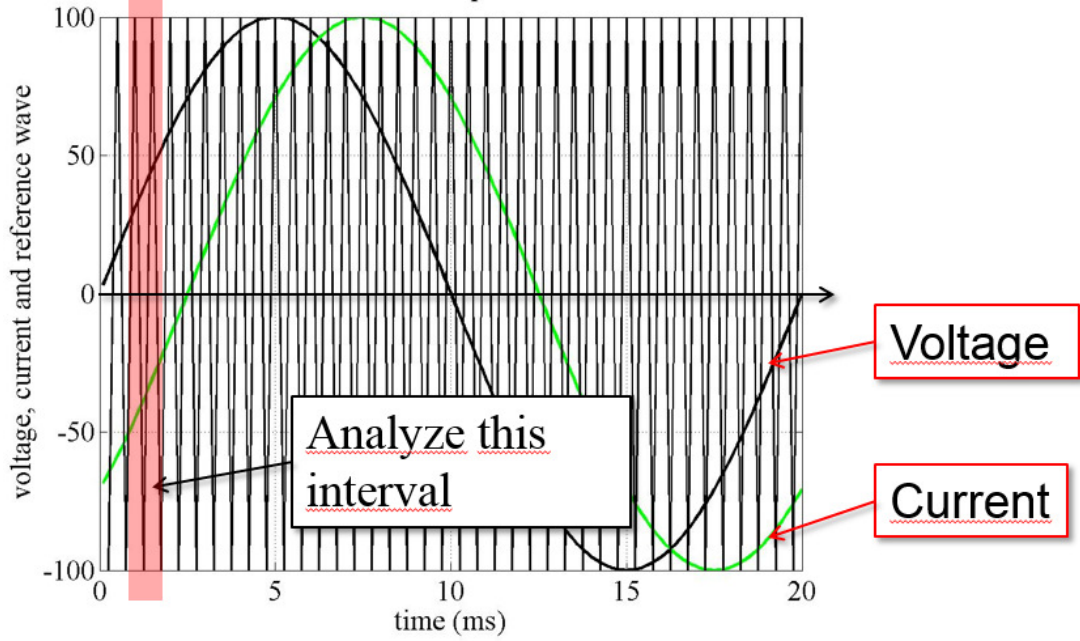

D_{A+}, D_{B-}
 T_{A-}, D_{B-}

- 11) Consider a neutral point diode clamped (NPC) 3-level inverter that consists of three parallel phase legs as the one depicted below. Draw the resulting mid-point voltages (v_{AGND} , v_{BGND} , v_{CGND}) and the resulting voltage (v_{An}) that is applied over a y-connected load (phase voltage). (4p)

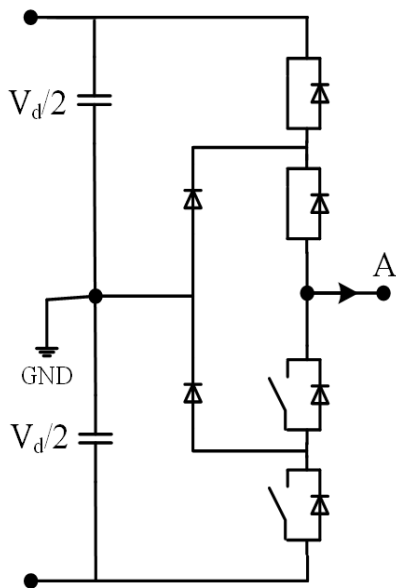

$$v_{An} = \frac{2}{3}v_{AGND} - \frac{1}{3}(v_{BGND} + v_{CGND})$$

The resulting voltage can be drawn as follows:

- Bus-splitting common DC-capacitor and diodes for clamping
- The resulting phase voltage will have 4 levels

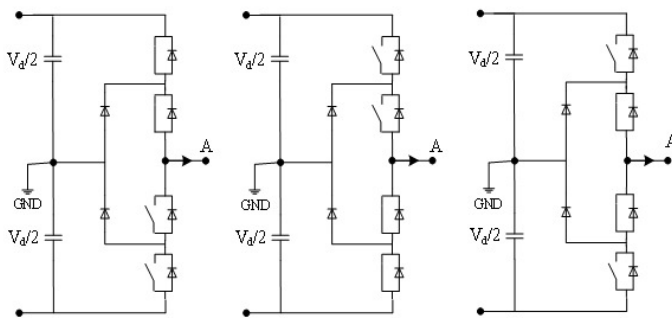

$$v_{An} = \frac{2}{3}v_{AGND} - \frac{1}{3}(v_{BGND} + v_{CGND})$$

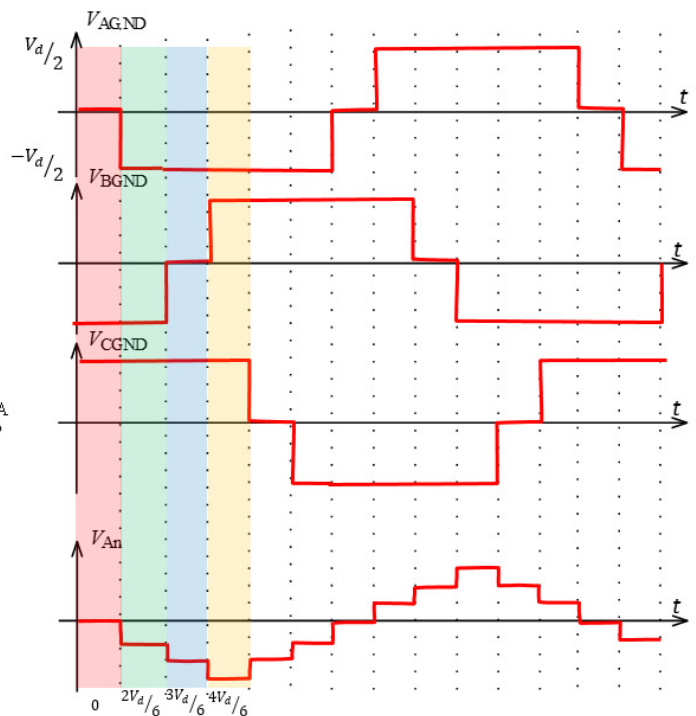

- 12) A dynamic thermal characteristics of a power module can be represented with the thermal network below. The system is exposed to a pulsed power source where each pulse is 3W and lasts for 10seconds. After the power pulse, the module is cooled to the previous temperature. If the module is assumed to operate in an ambient temperature of 100°C and with the minimum footprint, how many thermal cycles will the module survive before it breaks down? Due to which mechanism will it break down? (3p)

The pulse lasts for 10s which gives a transient thermal response of 30°C/W. Since the power dissipation in each pulse is 3W, the total temperature increase will be 90°C.

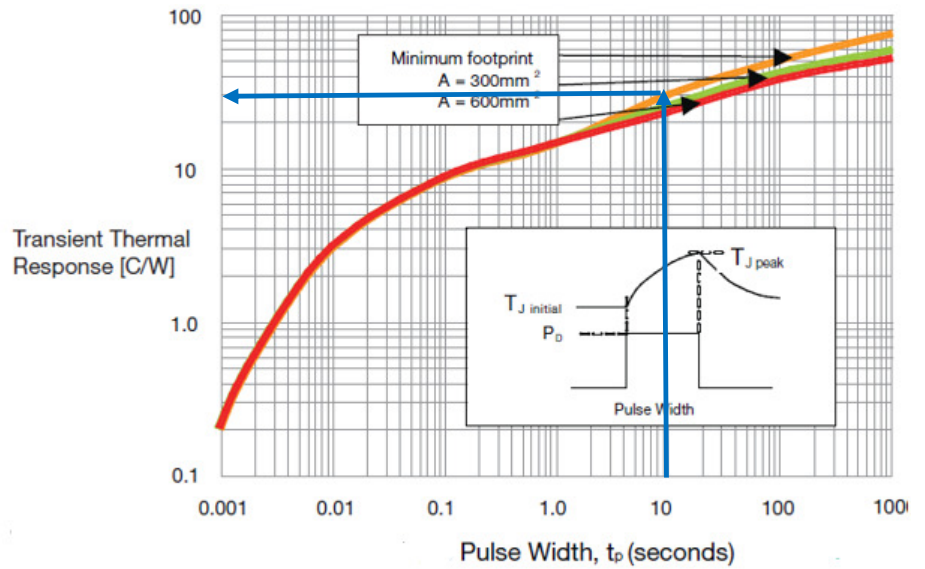
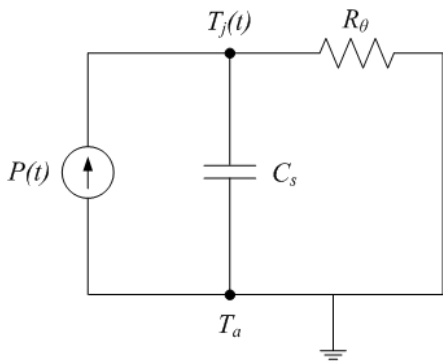

Power Cycling Capability for Modules

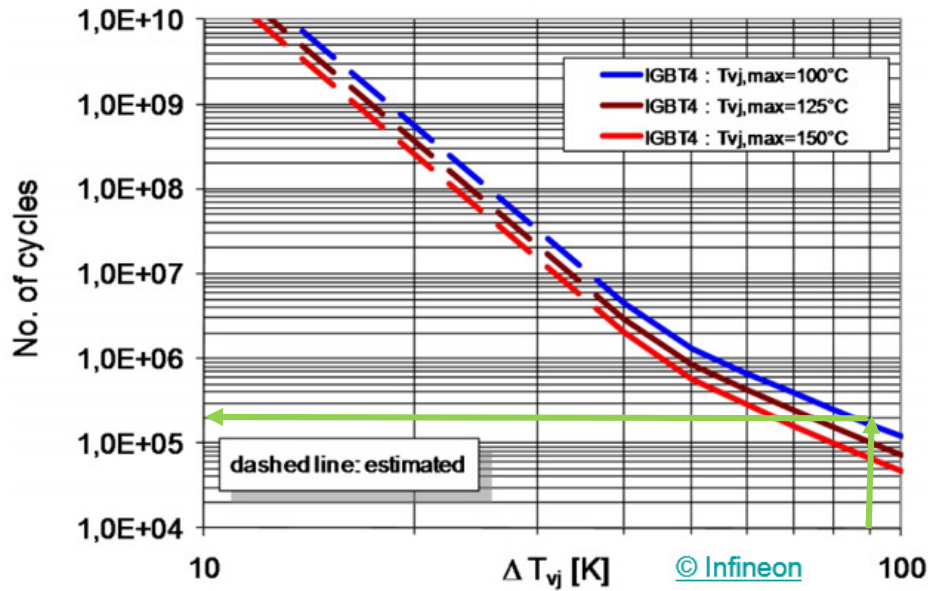

13) Consider the single phase thyristor rectifier with source inductance below.

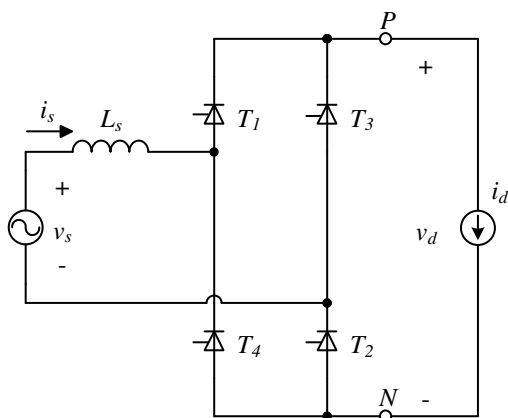

If the input is a triangular wave shaped voltage with an amplitude of 100V (peak) at a frequency of 60 Hz, draw the output voltage waveform (v_d) and calculate the average value V_d if the delay angle (α) is 45° and the source inductance (L_s) is 2mH. Assume that the DC-side current (i_d) is constant 10A. (5p)

The input voltage (v_s) and the output voltage (v_d) can be drawn as:

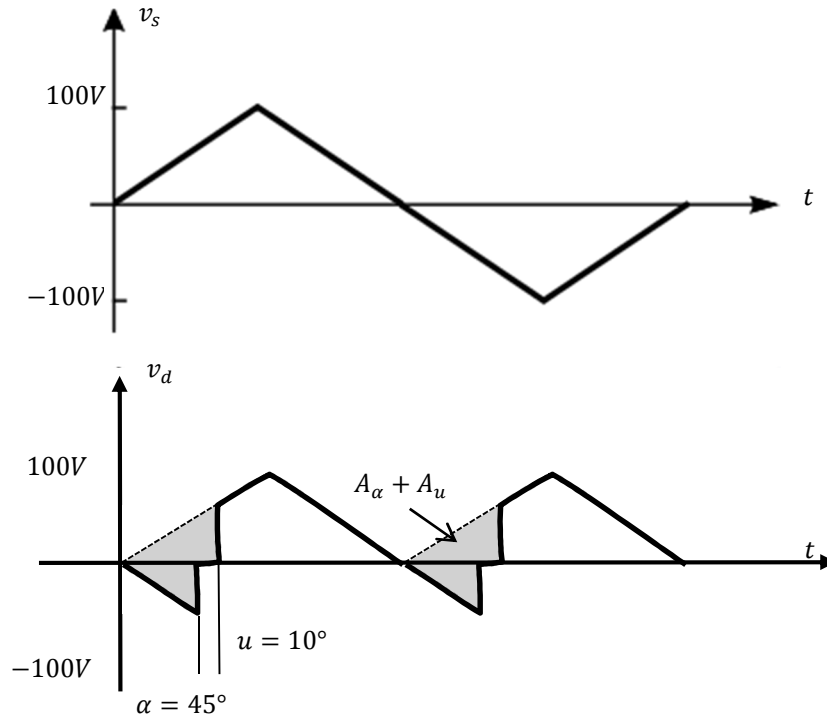

The reduction in output voltage due to the commutation can be expressed as an area:

$$v_s = v_{L_s} = L_s \frac{di_s}{dt}$$

$$\int_{45^\circ}^{45^\circ+u} \left(\frac{100}{\pi/2} \omega t \right) d\omega t = \omega L_s \int_{-I_d}^{I_d} di_s = 2\omega L_s I_d = A_u$$

$$V_d = V_{d(0)} - \frac{A_\alpha}{\pi} - \frac{A_u}{\pi} = \frac{V_{ampl}}{2} - 2 \frac{V_{ampl}/4 \cdot \alpha}{\pi} - \frac{2\omega L_s I_d}{\pi} \rightarrow V_d = 32.7V$$

14) **What are the main benefits of using 12-pulse rectification in a three-phase thyristor application (e.g. a HVDC classic transmission line)? Exemplify with e.g. input current and output voltage. (3p)**

- To reduce line current THD
- To improve input power factor
- To avoid semiconductor devices in series.

For a 6-pulse rectifier, the THD in the line current is high and the PF is low due to harmonics. For a corresponding 12-pulse rectifier, the THD in the line current is significantly lower and the PF is almost unity.

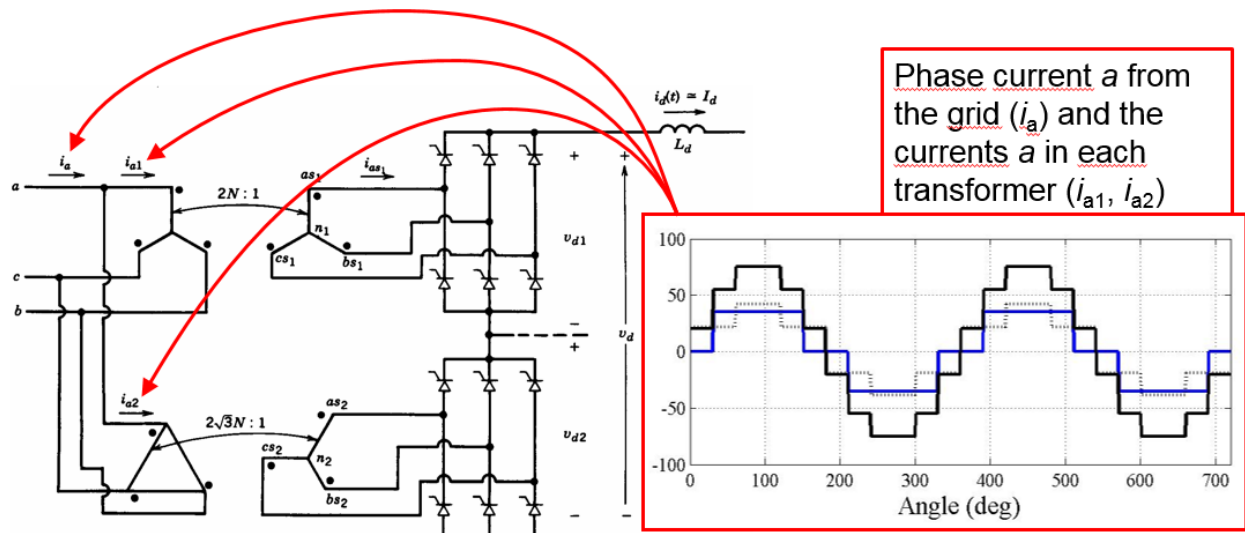

The resulting output DC-link voltage will be smoother (lower harmonic content) since it will consist of two voltages from each thyristor rectifier that are summed together with 30° phase difference.

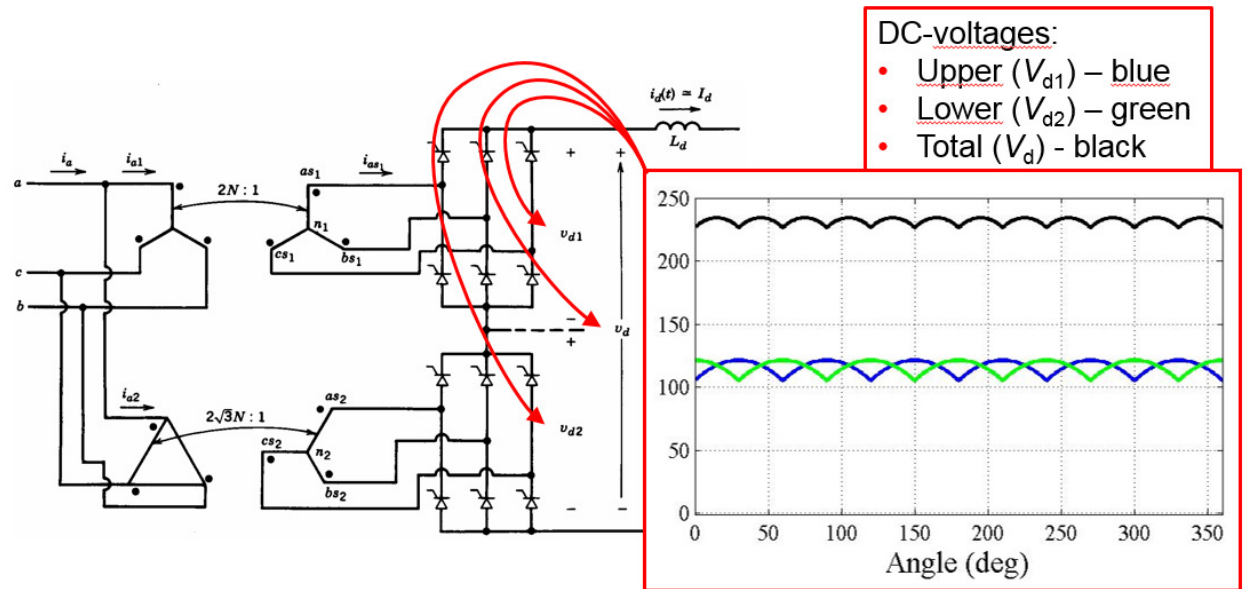

Formulas for Examination in Power Electronic Converters (ENM060)

Table 3-1 Use of Symmetry in Fourier Analysis

Symmetry	Condition Required	a_h and b_h	
Even	$f(-t) = f(t)$	$b_h = 0$	$a_h = \frac{2}{\pi} \int_0^{\pi} f(t) \cos(h\omega t) d(\omega t)$
Odd	$f(-t) = -f(t)$	$a_h = 0$	$b_h = \frac{2}{\pi} \int_0^{\pi} f(t) \sin(h\omega t) d(\omega t)$
Half-wave	$f(t) = -f(t + \frac{1}{2}T)$	$a_h = b_h = 0$ for even h	$a_h = \frac{2}{\pi} \int_0^{\pi} f(t) \cos(h\omega t) d(\omega t)$ for odd h
			$b_h = \frac{2}{\pi} \int_0^{\pi} f(t) \sin(h\omega t) d(\omega t)$ for odd h
Even quarter-wave	Even and half-wave	$b_h = 0$ for all h	$a_h = \begin{cases} \frac{4}{\pi} \int_0^{\pi/2} f(t) \cos(h\omega t) d(\omega t) & \text{for odd } h \\ 0 & \text{for even } h \end{cases}$
Odd quarter-wave	Odd and half-wave	$a_h = 0$ for all h	$b_h = \begin{cases} \frac{4}{\pi} \int_0^{\pi/2} f(t) \sin(h\omega t) d(\omega t) & \text{for odd } h \\ 0 & \text{for even } h \end{cases}$

Definition of RMS-value:

$$F_{RMS} = \sqrt{\frac{1}{T} \int_{t_0}^{t_0+T} f(t)^2 dt}$$

Definition of RMS-value with Fourier-series:

$$F_{RMS} = \sqrt{F_0^2 + \sum_{n=1}^{\infty} F_n^2} = \sqrt{\left(\frac{a_0}{2}\right)^2 + \sum_{n=1}^{\infty} \left(\frac{\sqrt{a_n^2 + b_n^2}}{\sqrt{2}}\right)^2}$$

$$\sin^2(\alpha) + \cos^2(\alpha) = 1$$

$$\sin(\alpha + \beta) = \sin(\alpha) \cos(\beta) + \cos(\alpha) \sin(\beta)$$

$$\cos(\alpha + \beta) = \cos(\alpha) \cos(\beta) - \sin(\alpha) \sin(\beta)$$

$$\sin(\alpha) \sin(\beta) = \frac{1}{2} (\cos(\alpha - \beta) - \cos(\alpha + \beta))$$

$$\cos(\alpha) \cos(\beta) = \frac{1}{2} (\cos(\alpha - \beta) + \cos(\alpha + \beta))$$

$$\int \sin(ax) dx = -\frac{1}{a} \cos(ax), \quad \int x \sin(ax) dx = \frac{1}{a^2} (\sin(ax) - ax \cos(ax)), \quad \int \cos(ax) dx = \frac{1}{a} \sin(ax)$$

$$\int x \cos(ax) dx = \frac{1}{a^2} (\cos(ax) + ax \sin(ax))$$

$$PF = \frac{P}{S} = \frac{V_s I_{s1} \cos \phi_1}{V_s I_s}, \quad DPF = \cos \phi_1, \quad \%THD_i = 100 \frac{I_{dis}}{I_{s1}} = 100 \frac{\sqrt{I_s^2 - I_{s1}^2}}{I_{s1}} = 100 \sqrt{\sum_{h \neq 1} \left(\frac{I_{sh}}{I_{s1}}\right)^2}$$

Electromagnetics

$$e = \frac{d}{dt} \psi \quad \psi = N\phi \quad \phi = BA \quad R = \frac{l}{A\mu_r\mu_0} \quad L = \frac{\Psi}{i}$$

$$NI = R\phi = mmf \quad N\phi = LI \quad L = A_L N^2 \quad W = \frac{1}{2} LI^2$$

Simpson's rule

Let $f(x)$ be a polynomial of maximum third degree, this means

$$f(x) = a_1 + a_2 x + a_3 x^2 + a_4 x^3$$

For this function the integral can be calculated as

$$\frac{1}{T} \int_{t_0}^{t_0+T} f(x) dx = \frac{1}{6} \left(f(t_0) + 4f\left(t_0 + \frac{T}{2}\right) + f(t_0 + T) \right)$$